



Works Approval

Works approval number	W6907/2024/1
Works approval holder	Premier Metals Corporation Pty Ltd
ACN	635 161 992
Registered business address	87 Kelvin Road Maddington WA 6109
DWER file number	INS-0002741
Duration	22/07/2024 to 21/07/2029
Date of issue	22/07/2024
Date of amendment	15/12/2025
Premises details	Premier Metal Recyclers 87 and 89 Kelvin Road Maddington WA 6109 Legal description - Lot 25 on Diagram 90351 Certificate of Title Volume 2062 Folio 394 and Lot 201 on Deposited Plan 30719 Certificate of Title Volume 1159 Folio 415 As defined by the coordinates in Schedule 2

Prescribed premises category description (Schedule 1, <i>Environmental Protection Regulations 1987</i>)	Assessed design capacity
Category 47: Scrap metal recovery: premises (other than premises within category 45) on which metal scrap is fragmented or melted, including premises on which lead acid batteries are reprocessed.	100,000 tonnes per annual period

This works approval is granted to the works approval holder, subject to the attached conditions, on 15 December 2025, by:

Abbie Crawford
MANAGER, WASTE INDUSTRIES
an officer delegated under section 20 of the Environmental Protection Act 1986 (WA)

Works approval history

Date	Reference number	Summary of changes
22/07/2024	W6907/2024/1	Works approval granted.
15/12/2025	W6907/2024/1	Amendment application (APP-0031222) to amend the prescribed premises boundary and the inclusion of a shear baler and weighbridge.

Interpretation

In this works approval:

- (a) the words ‘including’, ‘includes’ and ‘include’ in conditions mean “including but not limited to”, and similar, as appropriate;
- (b) where any word or phrase is given a defined meaning, any other part of speech or other grammatical form of that word or phrase has a corresponding meaning;
- (c) where tables are used in a condition, each row in a table constitutes a separate condition;
- (d) any reference to an Australian or other standard, guideline, or code of practice in this works approval:
 - (i) if dated, refers to that particular version; and
 - (ii) if not dated, refers to the latest version and therefore may be subject to change over time;
- (e) unless specified otherwise, any reference to a section of an Act refers to that section of the EP Act; and
- (f) unless specified otherwise, all definitions are in accordance with the EP Act.

NOTE: This works approval requires specific conditions to be met but does not provide any implied authorisation for other emissions, discharges, or activities not specified in this works approval.

Works approval conditions

The works approval holder must ensure that the following conditions are complied with:

Construction phase

Infrastructure and equipment

1. The works approval holder must:
 - (a) construct and/or install the infrastructure and/or equipment;
 - (b) in accordance with the corresponding design and construction / installation requirements; and
 - (c) at the corresponding infrastructure location as set out in Table 1.

Table 1: Design and construction / installation requirements

	Infrastructure	Design and construction / installation requirements	Infrastructure location
1.	Drake 16HP High Production Shredding System	<p>The shredder system must be installed in accordance with manufacturers recommendations.</p> <p>The shredder system must consist of all components as depicted in Schedule 1, Figure 3, including the following key components;</p> <ul style="list-style-type: none"> - Central body - Feed station with transmission line - Propulsion system - Grinding chamber and hammer rotor - Dust suction system - Transport line with vibrators and magnets - Conveyor belts 	Schedule 1 Figure 3
2.	Lefort Konkeror 1000 Shear Baler	<p>The shear baler must be installed in accordance with manufacturers recommendations.</p> <p>Must be installed on a hardstand area.</p>	N/A
3.	Concrete noise barrier	<p>A concrete noise barrier must be constructed at the eastern and southern boundaries of the shredder system and generator.</p> <p>The noise barrier must be designed and constructed to meet the following specifications:</p> <ul style="list-style-type: none"> - Typical barrier construction to be 12 mm compressed fibre cement with internal lining of acoustic absorbent material with minimum Noise Reduction Coefficient (NRC) 0.8. - The overall surface mass of the barrier is to be minimum 18 kg/m² with no gaps in the structure. 	Schedule 1 Figure 2

	Infrastructure	Design and construction / installation requirements	Infrastructure location
		- Minimum height of the noise barrier to be 5 m.	
4.	Fire hydrant system.	The fire hydrant system must be installed in accordance with the proposed fire hydrant system as depicted in Schedule 1, Figure 4.	Schedule 1 Figure 4
5.	Hardstand	A concrete hardstand must be constructed on Lot 201 and incorporate engineered drainage and sediment traps.	Schedule 1 Figure 5
6.	Weighbridges	Weighbridge must be installed in accordance with manufacturers recommendations.	Schedule 1 Figure 5
7.	Boundary fencing	A Colorbond fence must be installed around Lot 201, including secure access gates to restrict unauthorised entry.	Schedule 1 Figure 5

Compliance reporting

2. The works approval holder must within 30 days of an item of infrastructure or equipment required by condition 1 being constructed and/or installed:
 - (a) undertake an audit of their compliance with the requirements of condition 1; and
 - (b) prepare and submit to the CEO an Environmental Compliance Report on that compliance.
3. The Environmental Compliance Report required by condition 2, must include as a minimum the following:
 - (a) certification by a suitably qualified person that the items of infrastructure or component(s) thereof, as specified in condition 1, have been constructed in accordance with the relevant requirements specified in condition 1;
 - (b) as constructed plans and a detailed site plan for each item of infrastructure or component of infrastructure specified in condition 1; and
 - (c) be signed by a person authorised to represent the works approval holder and contains the printed name and position of that person.

Time limited operations phase

Commencement and duration

4. The works approval holder may only commence time limited operations for an item of infrastructure identified in condition 1 where the Environmental Compliance Report as required by condition 2 has been submitted by the works approval holder for that item of infrastructure; and
5. The works approval holder may conduct time limited operations for an item of infrastructure specified in condition 6:
 - (a). for a period not exceeding 180 calendar days from the day the works approval holder meets the requirements of condition 4 for that item of infrastructure; or

- (b). until such time as a licence for that item of infrastructure is granted in accordance with Part V of the *Environmental Protection Act 1986*, if one is granted before the end of the period specified in condition 5(a).

Time limited operations requirements

- 6. During time limited operations, the works approval holder must ensure that the premises infrastructure and equipment listed in Table 2 and located at the corresponding infrastructure location is maintained and operated in accordance with the corresponding operational requirement set out in Table 2.

Table 2: Infrastructure and equipment requirements during time limited operations

	Site infrastructure and equipment	Operational requirement	Infrastructure location
1	Drake 16HP High Production Shredding System	Must be maintained in accordance with manufacturer’s specifications. Must be operated on hardstand area.	Schedule 1 Figure 2
2	Shear balers	Must be operated in a manner that ensures that noise emissions comply with the <i>Environmental Protection (noise) Regulations 1997</i> .	
3	Vehicle dismantling area	Must be self-bunded and maintained free of leaks and defects.	Schedule 1 Figure 2
4	Shredded steel stockpile area	Must be positioned on a hardstand area and maintained free of leaks and defects.	Schedule 1 Figure 2
5	Light gauge steel stockpile area		
6	Scrap floc storage area		
7	Heavy steel stockpiles area		
8	Sheared steel stockpile area		
9	Oxy cutting area and equipment		
10	Refuelling station	Must be positioned on a bunded hardstand area and maintained free of leaks and defects.	Schedule 1 Figure 2
11	Noise barrier	Must be maintained free of gaps and defects.	Schedule 1 Figure 2
12	Stormwater Infrastructure	Stormceptor Class 1 system and oil water separators to be maintained in good working order;	Schedule 1 Figure 2

		All concrete hardstands to be maintained free of deficiencies; and All drains and pipe to be kept free of waste at all times.	
13	Fire management and prevention equipment	All on site fire management and prevention equipment must be maintained in good working order.	Schedule 1 Figure 4
14	Weighbridges	Must be maintained in accordance with manufacturer's specifications	Schedule 1 Figure 5
15	Fence	<ul style="list-style-type: none"> Maintained around the entire perimeter of the premises; and Ensure that any entrance gates to the premises are securely locked when the premises is unattended 	Schedule 1 Figure 5

Waste acceptance

7. The works holder must only accept onto the premises waste of a waste type that;
- (a) does not exceed the corresponding rate at which waste is received, and
 - (b) meets the corresponding acceptance specification,
- as set out in Table 3.

Table 3: Types of waste authorised to be accepted onto the premises

Waste type	Rate at which waste is received	Acceptance specifications
Scrap metal (ferrous and non-ferrous)	Combined total of 100,000 tonnes per annual period	<ul style="list-style-type: none"> (a). Car bodies (b). Machinery (c). Light gauge (mixed) scrap (d). Heavy gauge Steel (e). Non – Ferrous (f). E Waste
Hazardous waste (used lead acid batteries)		Acceptance of used lead acid batteries only, for storage and disposal offsite. No other hazardous waste shall be accepted.

8. The works approval holder must ensure that where waste does not meet the waste acceptance criteria set out in condition 7, it is removed from the premises by the delivery vehicle or, where that is not possible, stored in a quarantined storage area or container and removed to an appropriately authorised facility as soon as practicable.

Waste processing

9. The works approval holder must ensure that the waste types specified in Table 3 are only subjected to the corresponding process(es), subject to the corresponding process limits and/or specifications.

Table 4: Waste processing

Waste type	Process(es)	Process limits and/or specifications
Scrap metal (ferrous and non – ferrous)	Receipt, handling, sorting, baling, shearing, flame cutting, compacting and storage prior to sale or removal offsite.	<p>Acceptance Requirement:</p> <ul style="list-style-type: none"> • Inspection of all materials received at the premises for the removal of non-conforming waste and hazardous waste, including, but not limited to. used pressure vessels (for example, liquid petroleum gas (LPG), oxygen, acetylene or any other gas cylinders), non-metallic refuse (for example, tyres, foam), chemical substances (for example, pool chlorine, paints), hazardous substances (for example, syringes, needles, and sharps), flammable or explosive substances (for example, fuels and solvents), poisonous materials (for example, bleaches, cleaning products and disinfectants), closed or sealed containers, drums that have not been neutralised and certified as clean with tops removed and radioactive material. If any of these wastes are found, they are required to be removed before further processing; • Any item that are suspected of containing asbestos must be removed prior to further processing; and • All items that may have contained gasses must be de-gassed prior to acceptance onto the premises. <p>Storage requirements:</p> <ul style="list-style-type: none"> • No more than 100 tyres stored at any one time; • Floc stockpile must not exceed 350 m³ and must be stored on a bunded hardstand; • All stockpiles must not exceed 5 m in height at any point from the base of the stockpile; • Minimum of 16 m clearance must be maintained between each stockpile; • Batteries to be stored in an undercover bunded hardstand area; and • Waste fluids from the vehicles such as brake fluid, engine oil, radiator coolants etc. must be stored undercover and bunded area. <p>Processing requirements:</p> <ul style="list-style-type: none"> • All material with the potential to generate dust must be wetted prior to shearing, bailing, handling and cutting;
Hazardous waste (used lead acid batteries)	Acceptance and storage prior to removal from the premises.	

Waste type	Process(es)	Process limits and/or specifications
		<ul style="list-style-type: none"> • The shredder system must be used in conjunction with the dust suction system as depicted in Schedule 1, Figure 3; • Car de-pollution activities to be undertaken on a bunded hardstand area prior to baling, shearing, shredding or compaction activities; • All liquid waste from the vehicle must be drained prior to dismantling and the processing area must flow into a sump containing a dedicated oil water separator; • Prior to any oxy-cutting activities, the immediate area within the oxy/plasma cutting area must be wetted down to reduce the risk of ignition from sparks and/or molten metal; • Oxy-cutting area must be kept free of combustible materials including vegetation and organic litter; and • Any combustible materials that cannot be removed must be covered using suitable guards or covers during oxy cutting activities

Emission and discharge

10. The works approval holder must ensure that:
 - (a). all reasonable and practicable measures are taken to ensure that no windblown waste escapes from the premises; and
 - (b). any windblown waste is collected on at least a weekly basis and returned to appropriately contained.
11. The works approval holder must ensure that no visible dust generated from the primary activities crosses the boundary of the premises.
12. The works approval holder must ensure that noise generating activities at the premises only occur Monday to Friday between the hours of 07:00 and 17:00, and on Saturday between the hours of 08:00 and 13:00.
13. The works approval holder must immediately recover, or remove and dispose of, spills of environmentally hazardous materials including fuel, oil, or other hydrocarbons, whether inside or outside an engineered containment system.
14. The works approval holder must ensure that all material used for the recovery, removal, and/or disposal of environmentally hazardous materials is stored in an impermeable container prior to disposal at an appropriately authorised facility.
15. The works approval holder must take all reasonable and practicable measures to prevent stormwater run-off becoming contaminated by the activities and operations undertaken at the premises.
16. The works approval holder must ensure that all emissions specified in Table 5, are discharged only from the corresponding discharge point and only at the corresponding discharge point location.

Table 5: Authorised discharge points

Emission	Discharge point	Discharge point location
Treated stormwater	Final discharge point	As depicted in Schedule 1, Figure 2

17. The works approval holder must ensure that emissions from the discharge point listed in Table 6 for the corresponding parameter do not exceed the corresponding limit listed in Table 6, when monitored in accordance with condition 20.

Table 6: Emission and discharge limits

Discharge point	Parameter	Limit
Final discharge point (As depicted in Schedule 1, Figure 2)	Total Recoverable Hydrocarbons	1 mg/L

Monitoring during time limited operations

18. The works approval holder must record the total amount of waste accepted onto and removed from the premises, for each waste type listed in Table 7, in the corresponding unit, and for each corresponding time period, as set out in Table 7.

Table 7: Waste accepted onto the premises

Waste type	Unit	Time period	Frequency
Waste input	m ³ or tonnes	Annual period	Each load arriving at the premises
Waste output	m ³ or tonnes		Each load leaving or rejected from the premises

19. The works approval holder must ensure that for all samples obtained in accordance with condition 20, analysis is undertaken by a holder of a current accreditation from the National Association of Testing Authorities (NATA) for the methods of sampling and analysis relevant to the corresponding parameters, unless otherwise specified.
20. The works approval holder must monitor treated stormwater for concentrations of the identified parameter(s) in accordance with the requirements specified in Table 8.

Table 8: Stormwater monitoring requirements

Monitoring location	Parameter	Units	Averaging period	Frequency	Method
Stormceptor outlet (as depicted in Schedule 1, Figure 2)	pH ¹	-	Spot sample	Quarterly ² during time limited operations	Spot sample, in accordance with AS/NZS 5667.1 and AS/NZS 5667.10
	Electrical conductivity	µS/cm			
	Total Recoverable Hydrocarbons	mg/L or µg/L			
	Aluminum				
	Arsenic				
	Cadmium				
	Chromium (III)				
Chromium (VI)					

Monitoring location	Parameter	Units	Averaging period	Frequency	Method
	Copper				
	Manganese				
	Nickel				
	Lead				
	Zinc				
	Benzene, toluene, ethylbenzene & xylenes (BTEX)				
	Total Polycyclic Aromatic Hydrocarbons (PAH)				
	Napthalene				
	Total Polychlorinated biphenyls (PCB)				
	Trichloroethane (TCE)				
	Tetrachloroethane (PCE)				

Note 1: In-field non-NATA accredited sampling permitted

Note 2: Quarterly monitoring must be undertaken at least 45 days apart

Fire and emergency management

21. The works approval holder must ensure that no waste is burnt on the premises.
22. The works approval holder must immediately notify the CEO of:
 - (a) any fire on the premises; and/or
 - (b) any accident, malfunction, or emergency which results or could result in the discharge of fire-fighting washwater or other wastes from the premises.
23. The works approval holder must implement a Fire and Emergency Management Plan that is consistent with Australian Standard AS3745. The plan must include, but is not limited to:
 - (a) notification procedures for fire and major spill incidents;
 - (b) how fires will be prevented, detected, responded to, suppressed, contained and controlled for all approved activities addressing all waste types and for all stages of the waste handling, sorting and processing;
 - (c) in the event of a fire occurring at the premises, how impacts to the environment and human health will be mitigated;
 - (d) how staff will be trained in fire and emergency response on an ongoing, annual basis;
 - (e) details on the firefighting equipment in place and/or accessible at the premises and the fire response capabilities and responsibilities;
 - (f) a premises map displayed at the front of the premises depicting an after-hours contact details, plus the location and layout of:
 - (i) fire hose reels, hydrants and isolation points;
 - (ii) electrical isolation points;

- (iii) sub-surface drainage infrastructure, including details on flow direction and off-site discharge locations (if applicable);
 - (iv) system shutdown points; and
 - (v) fire response access points to the premises;
- (g) hazmat manifest displayed at front of the premises;
- (h) how fire water can be prevented from draining into stormwater drains.

Noise validation

- 24.** Within 60 days of the commencement date of time limited operations, the works approval holder must retain the services of a person qualified and experienced in the area of environmental noise assessment and who by their qualifications and experience is eligible to hold membership of the Australian Acoustical Society or the Australian Association of Acoustical Consultants to:
- (a). investigate the nature and extent of noise emissions from the premises;
 - (b). assess in accordance with the methodology required in the *Environmental Protection (Noise) Regulations 1997*, the compliance of the noise emissions from the primary activities, against the relevant assigned levels specified in those Regulations; and
 - (c). compile and submit to the works approval holder within 4 months of the commencement date of time limited operations a report in accordance with condition 25.
- 25.** A report prepared pursuant to condition 24(c) is to include:
- (a). a description of the methods used for monitoring and/or modelling of noise emissions from the premises;
 - (b). details and the results of the investigation undertaken pursuant to condition 24(a);
 - (c). details and results of the assessment of the noise emissions from the premises, against the relevant assigned levels in the *Environmental Protection (Noise) Regulations 1997* undertaken pursuant to condition 24(b); and
 - (d). an assessment of noise levels against the most recent previous noise assessment.
- 26.** The works approval holder must submit to the CEO the report prepared pursuant to condition 24(c) within 14 days of receiving it.
- 27.** Where an assessment pursuant to condition 24(b) indicates that noise emissions do not comply with the relevant assigned levels in the *Environmental Protection (Noise) Regulations 1997*, the license holder must:
- (a). within 60 days of receiving an assessment report pursuant to condition 24(c) prepare a plan to ensure the undertaking of the licensed activity will no longer lead to any contravention of the *Environmental Protection (Noise) Regulations 1997*; and
 - (b). provide to the CEO a copy of the plan prepared pursuant to condition 27(a) within 30 days of its preparation.

Compliance reporting

- 28.** The works approval holder must submit to the CEO a report on the time limited operations within 30 calendar days of the completion date of time limited operations or 30 calendar days before the expiration date of the works approval, whichever is the sooner.
- 29.** The works approval holder must ensure the report required by condition 28 includes the following:
- (a) a summary of monitoring results obtained during time limited operations under conditions 18 and 20;
 - (b) a review of performance and compliance against the conditions of the works approval; and
 - (c) where the manufacturer's design specifications and the conditions of this works approval have not been met, what measures will the works approval holder take to meet them, and what timeframes will be required to implement those measures.

Records and reporting (general)

- 30.** The works approval holder must record the following information in relation to complaints received by the works approval holder (whether received directly from a complainant or forwarded to them by the Department or another party) about any alleged emissions from the premises:
- (a) the name and contact details of the complainant, (if provided);
 - (b) the time and date of the complaint;
 - (c) the complete details of the complaint and any other concerns or other issues raised; and
 - (d) the complete details and dates of any action taken by the works approval holder to investigate or respond to any complaint.
- 31.** The works approval holder must maintain accurate and auditable books including the following records, information, reports, and data required by this works approval:
- (a) the works conducted in accordance with condition 1;
 - (b) any maintenance of infrastructure that is performed in the course of complying with condition 6;
 - (c) monitoring programmes undertaken in accordance with condition(s) 18 and 20; and
 - (d) complaints received under condition 30.
- 32.** The books specified under condition 31 must:
- (a) be legible;
 - (b) if amended, be amended in such a way that the original version(s) and any subsequent amendments remain legible and are capable of retrieval;
 - (c) be retained by the works approval holder for the duration of the works approval; and
 - (d) be available to be produced to an inspector or the CEO as required.

Definitions

In this works approval, the terms in Table 9 have the meanings defined.

Table 9: Definitions

Term	Definition
annual period	a 12 month period commencing from 1 January until 31 December of the same year.
AS/NZS 5667.1	means the Australian Standard <i>AS/NZS 5667.1 (R2016) Water quality – sampling – guidance of the design of sampling programs, sampling techniques and the preservation and handling of samples</i> , as amended from time to time
AS3745	means the Australian Standard AS3745 Planning for Emergencies in Facilities
books	has the same meaning given to that term under the EP Act.
CEO	means Chief Executive Officer. CEO for the purposes of notification means: Director General Department administering the <i>Environmental Protection Act 1986</i> Locked Bag 10 Joondalup DC WA 6919 info@dwer.wa.gov.au
Department	means the department established under section 35 of the <i>Public Sector Management Act 1994</i> and designated as responsible for the administration of Part V Division 3 of the EP Act.
discharge	has the same meaning given to that term under the EP Act.
emission	has the same meaning given to that term under the EP Act.
Environmental Compliance Report	means a report to satisfy the CEO that the conditioned infrastructure and/or equipment has been constructed and/or installed in accordance with the works approval.
EP Act	<i>Environmental Protection Act 1986 (WA)</i> .
EP Regulations	<i>Environmental Protection Regulations 1987 (WA)</i> .
NATA	means the National Association of Testing Authorities
NATA accredited	means in relation to the analysis of a sample, that the laboratory is NATA accredited for the specified analysis at the time of the analysis.
premises	the premises to which this works approval applies, as specified at the front of this works approval and as shown on the premises

Term	Definition
	map (Figure 1) in Schedule 1 to this works approval.
prescribed premises	has the same meaning given to that term under the EP Act.
suitably qualified person	<p>means a person who:</p> <ul style="list-style-type: none"> (a) holds a Bachelor of Engineering degree recognised by the Institute of Engineers; and (b) has a minimum of five years of experience working in the field of engineering; <p>or is otherwise approved in writing by the CEO to act in this capacity.</p>
time limited operations	refers to the operation of the infrastructure and equipment identified under this works approval that is authorised for that purpose, subject to the relevant conditions.
waste	has the same meaning given to that term under the EP Act.
works approval	refers to this document, which evidences the grant of the works approval by the CEO under section 54 of the EP Act, subject to the conditions.
works approval holder	refers to the occupier of the premises being the person to whom this works approval has been granted, as specified at the front of this works approval.

END OF CONDITIONS

Schedule 1: Maps

Premises map

The boundary of the prescribed premises is shown in the map below:

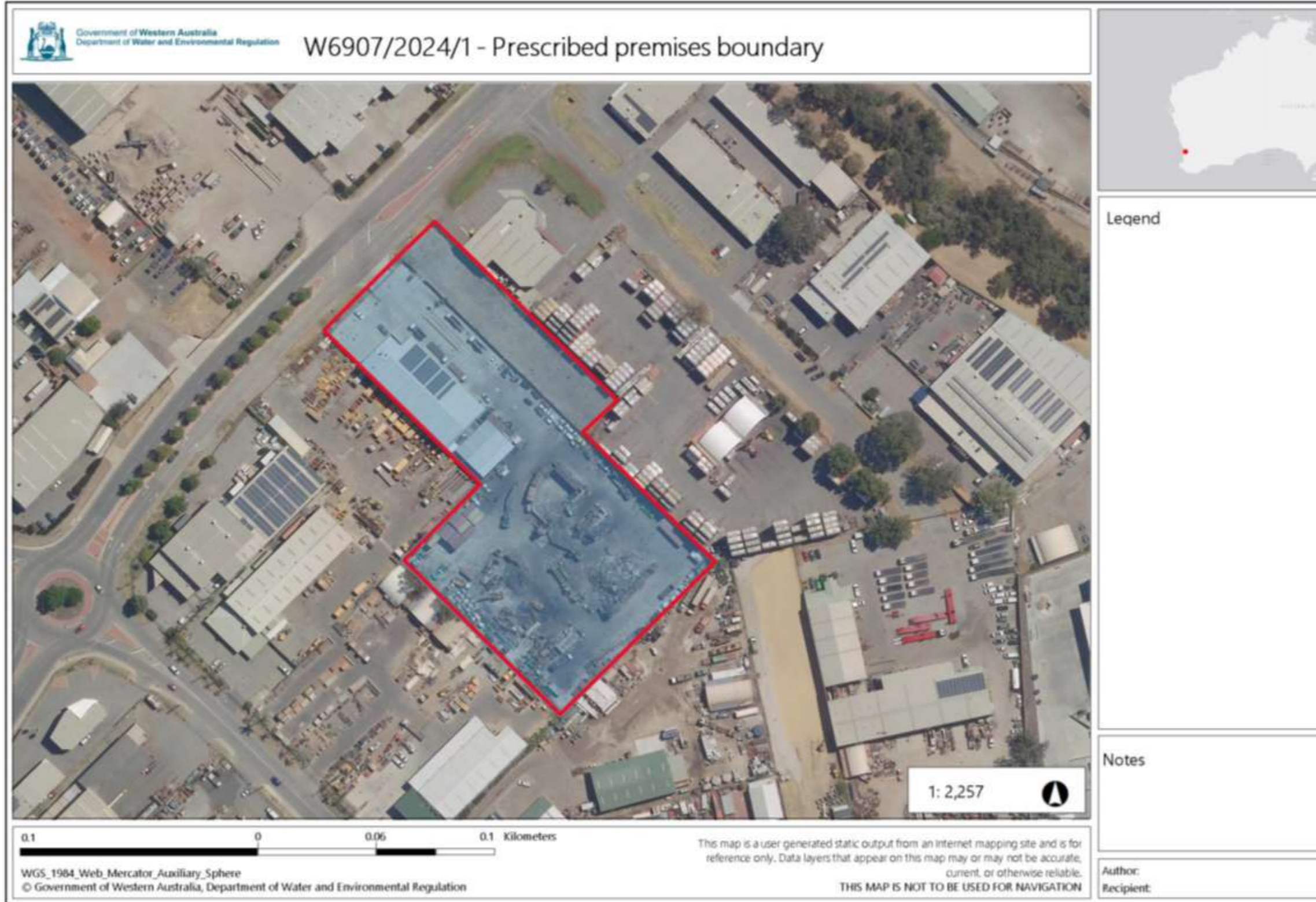

Figure 1: Map of the boundary of the prescribed premises

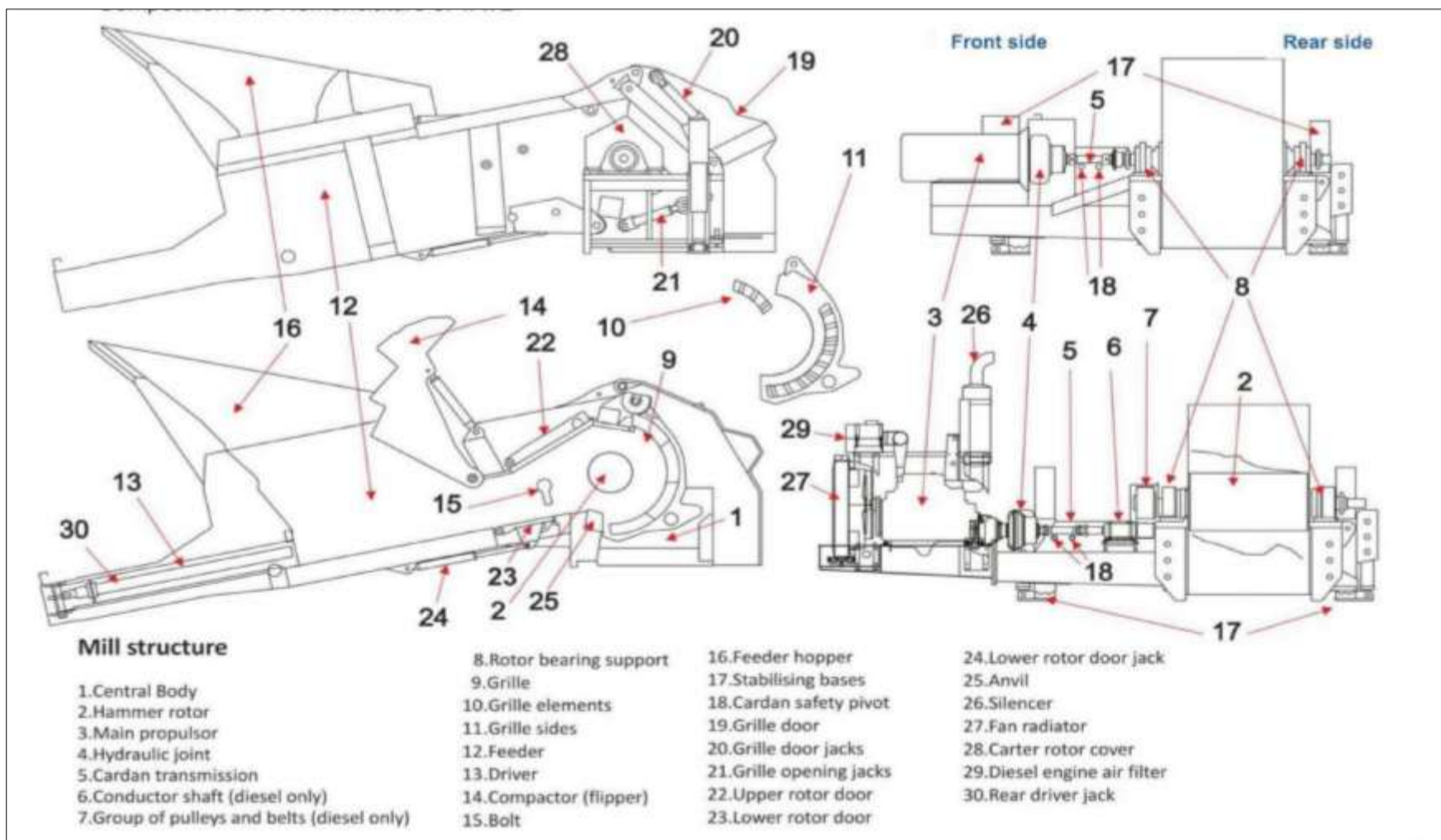
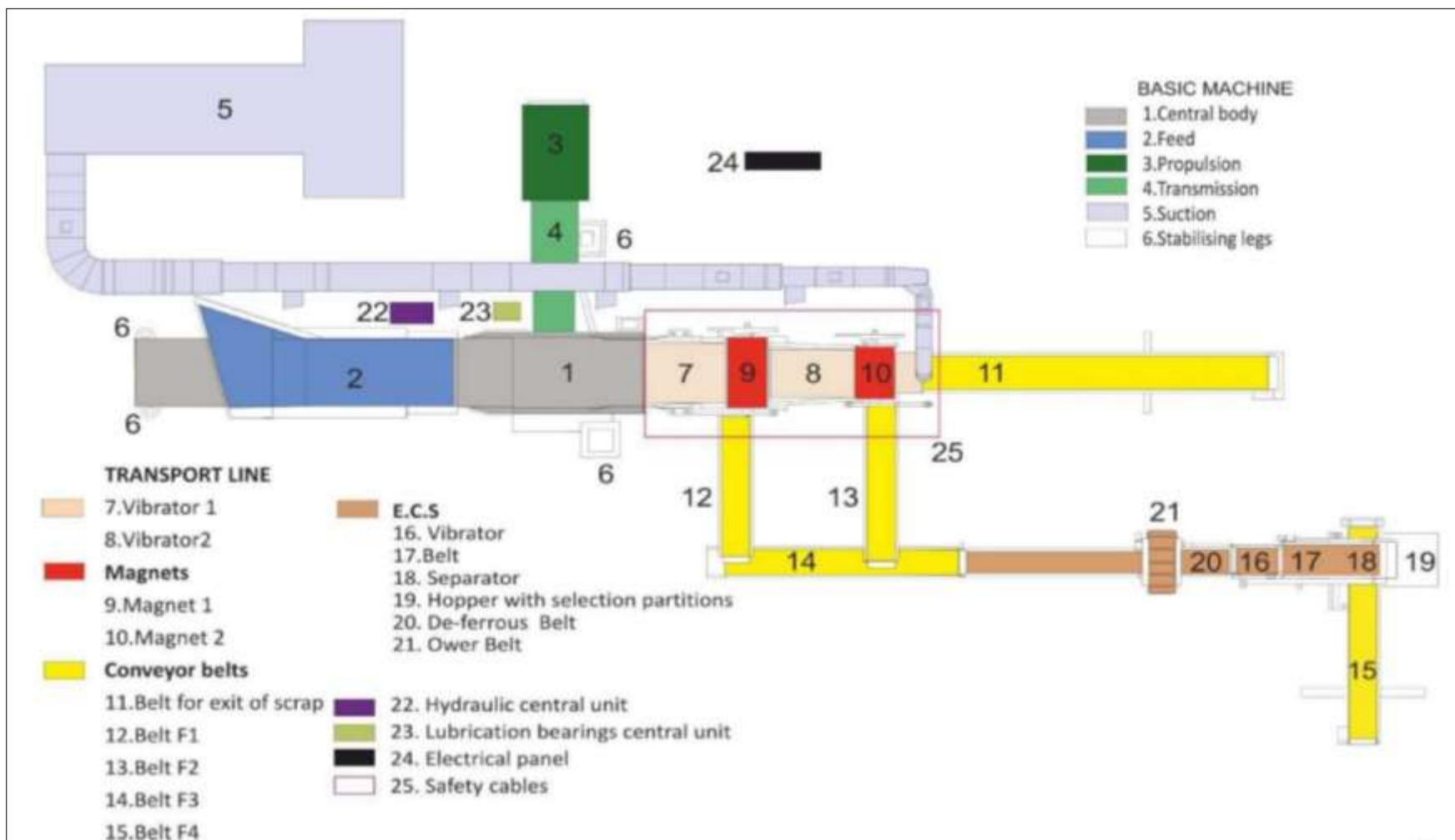

Figure 3: Basic structure of the shredder system

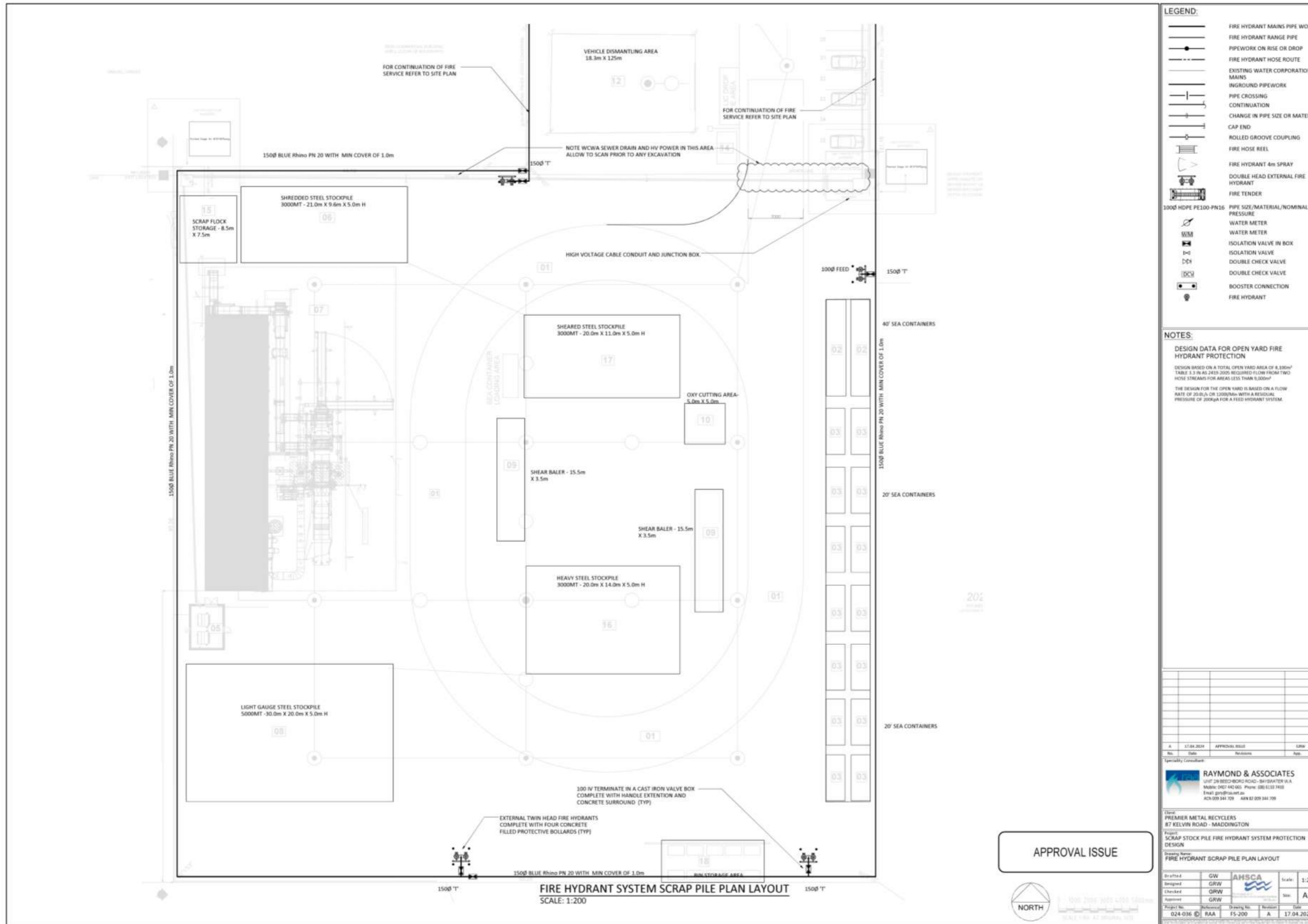

Figure 4: Proposed fire hydrant system for lot 25

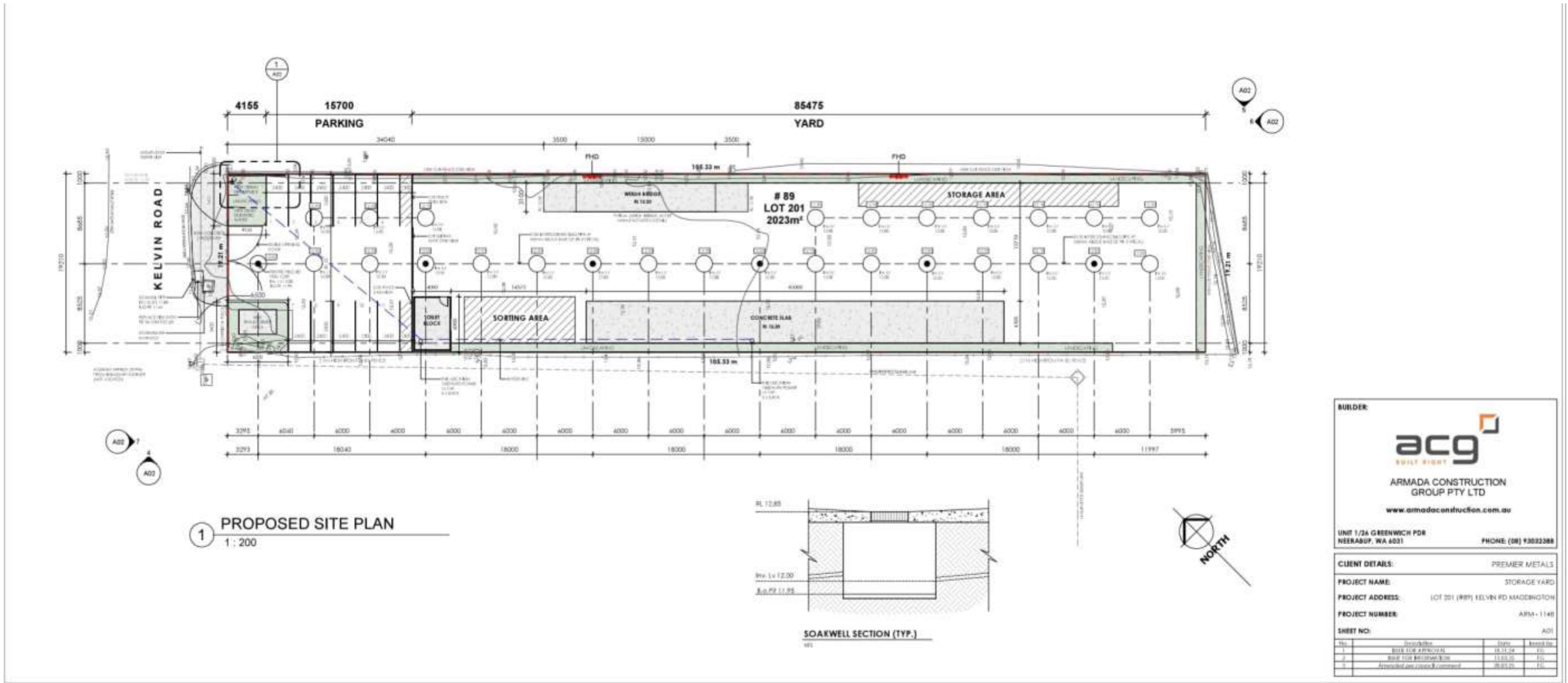

Figure 5: Proposed site layout for lot 201

Schedule 2: Premises boundary

The corners of the premises boundary are the coordinates listed in Table 10.

Table 10: Premises boundary coordinates (GDA2020)

	Easting	Northing	Zone
1.	404916.36684	6454548.68291	50
2.	404947.21523	6454582.22866	50
3.	404961.37276	6454594.68106	50
4.	405036.39879	6454520.64605	50
5.	405023.48653	6454507.29828	50
6.	405076.82329	6454454.83820	50
7.	405015.10605	6454389.96439	50
8.	404949.33756	6454455.86764	50
9.	404981.15061	6454487.20509	50